



## FLOOD & HIGH MAST FLOOD LIGHT V4 SERIES

This LED floodlight was designed for installation on facades, warehouses, billboards, yards, terraces, gardens, or any fixed outdoor application that allows mounting via the integrated rotatable bracket. This floodlight features a selectable power and color temperature system.

CERTIFICATIONS



NOM-003-SCF-2014  
NOM-031-ENER-2012

Technical Data	
Input voltage	100 - 277V V ~ (Multivoltage)
Input frequency	50 / 60 Hz
Dimmable	0 - 10 V
Color temperature	3000K, 4000K or 5000K
CRI	> 70
Operating temperature	-25 to 50° C
Harmonic distortion	<10 %
Power factor	0.90
Beam angle	120°
Mounting	Surface mounted: Bracket (included)
Clasification	IP66 - IK08
Anti-surge rating	10 kV
Lifespan	50,000 hours
Body	Die-cast A383 aluminum alloy
Optics	Borosilicate
Color	Black

Model	Adjustable Power	Adjustable CCT	Luminous Efficiency	Luminous Flux
SO	80W   60W   40W	3,000K   4,000K   5,000K	150 lm/W	Max. 12,000 lumens
MO	200W   150W   100W	3,000K   4,000K   5,000K	150 lm/W	Max. 30,000 lumens

Aluminum heat sink fins to optimize thermal management

Rotatable bracket included; rotates up to ±120° for flexible mounting on building tops, walls, or the ground

Adjustable system allows changing power and color temperature

100% 3,000K  
75% W 4,000K CCT  
50% 5,000K

### Control Systems





## DIMENSIONS

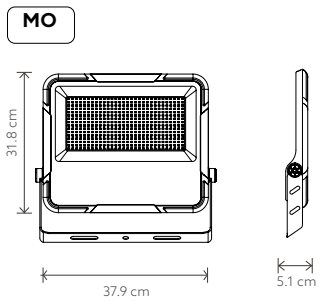
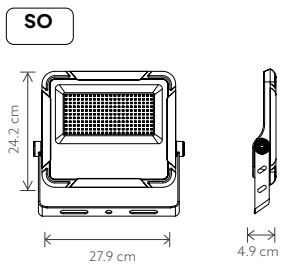

## PHOTOMETRIC DISTRIBUTION

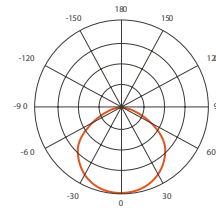

120°

## ORDERING GUIDE

<b>1 Series</b>	<b>2 Model</b>	<b>3 Control</b>
FL4	SO MO	N Ninguno I Jungo Connect

Code example:

<b>1 Series</b>	<b>5 Control</b>
<b>FL4</b>	<b>I</b>
	<b>MO</b>
	<b>2 Model</b>